

Derivation of Time Delay in Fiber Optic Communication

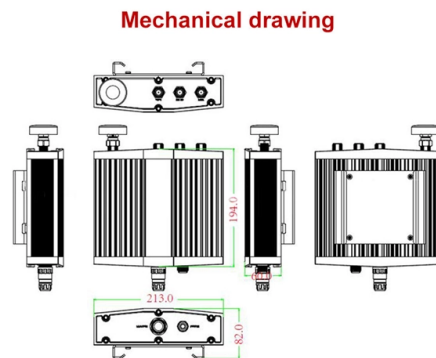

Overview

Electric power optical transmission technologies and devices have gone through PDH and SDH to the OTN era [7, 8]. The IEC2015 technical reported that SDH/SONET transmission technology is widely used to carry mission-critical services on production control networks, such as tele protection. In 2015, the OTN technology, as a new technology, attracted. Currently, small-granularity services such as tele protection and security- and stability-sensitive services are encapsulated using SDH/VC-12 and then mapped into ODU1/OTN. There is no OTN device that can directly add or drop these services [12, 13]. To efficiently carry production service signals at a rate lower than 1 Gbit/s, the flexible small-c. Low-rate services, packet services, and new services are adapted and mapped to OSUflex containers, and then multiplexed to higher-order ODUk/OTUk/OTUCn signals for transmission. Alternatively, OSU containers can be directly multiplexed into higher-order ODUk/OTUk/OTUCn signals for transmission. Compared with traditional ODUk, the OSU is more refined.

Article Content

Long-Term Latency Measurement of Deployed Fiber

ature but is dampened and has some time delay. Similar behavior was reported in , where the temperature in soil in different depths was measured. We modelled the temperature variation of the fiber as

High Precise Time Delay Measurement in Optical Fiber

Due to its properties of low attenuation, high capacity and reliability, the widespread optical fiber network has become an attractive option for long-distance transmission. The signal

Lecture6-228a.ppt

Lecture 6 - Propagation in Optical Fibers and Dispersion Non-Linear Schrodinger Equation Both linear (dispersive) and nonlinear effects must be taken into account for pulse propagation in the fiber

Passive Optical Network Fiber Length | Math Encounters

My focus in this post will be on fiber length determination for Gigabit Passive Optical Network (GPON) systems. Other Passive Optical Network (PON)

Latency in Fiber Optic Networks

For communications systems, latency is an important factor, because transmission delays can affect the quality and reliability of the system. In the case of fiber optic networks, latency is the time delay that

Time Delay Control Method of Optical Fiber Communication Network

Download Citation | On May 1, 2023, Yufei Liu published Time Delay Control Method of Optical Fiber Communication Network Based on Differential Evolution Algorithm | Find, read and cite...

Latency in Fiber Optic Networks

In fiber optical networks latency consists of three main components which adds extra time delay: opto-electrical components. Therefore, for the

High-precision time delay compensation to achieve a low noise floor in ...

In this paper, the linear interpolation technique is used to achieve high precision time delay compensation, making the time delay approaches zero and thereby achieving effective RIN

High Precise Time Delay Measurement in Optical Fiber

High Precise Time Delay Measurement in Optical Fiber Jingwen Dong, Bo Wang, Hongwei Si and Lijun Wang Abstract Due to its properties of low attenuation, high capacity and reliability, the widespread

Transmission Delay in Optical Fiber Communication System of Power ...

An OTN optical service unit (OSU) solution uses dedicated DM bytes for delay information transmission. The NMS can visualize network delay in real time, which is better than the manual delay evaluation

Optical Fiber Time Delay Comparison Between NIST and LAMETRO

Optical fiber-based communication relies on accurate optical fiber time delay measurements to determine accurate optical lengths of different elements within the optical network

Accurate Single-Ended Measurement of Propagation Delay in Fiber

Abstract—A correlation optical time-domain reflectometry (C-OTDR) method is presented, which measures the propagation delay with an accuracy of a few picoseconds. This accuracy is achieved

Transmission Delay in Optical Fiber Communication System of Power ...

However, fiber core resources are prone to waste and have short transmission distances. The other is multiplexing, which uses the 2 Mbit/s or 64 Kbit/s digital channel of an SDH optical fiber

High-accuracy optical time delay measurement in fiber link

In this paper, the recent advances in the optical time delay measurement of a fiber link with high accuracy are reviewed. The general models of the typical time delay measurement technologies are

How to Calculate Delay in Optical Fiber

Temporal delays or latency in optical fiber refer to the time it takes for a light signal to travel a certain distance from the source to the receiver. Despite

Throughput and Latency Performance Evaluation of an

Abstract The development of optical fiber has revolutionized the communications sector and played a crucial role in the information age.

Long-Term Latency Measurement of Deployed Fiber

81 Berlin, Germany fazendorf@advaoptical Abstract: Using a Correlation-OTDR we measured the latency of fibers in a deployed cable and calculated the temperature coefficient of the fiber temperature

Stabilized Time Transfer via a 1000-km Optical Fiber

The high-precision time delay compensation technology proposed in this paper can be applied to the optical fiber time synchronization system, and it

Practical Evaluation of a 50 km Fiber Link Utilizing a Commercial Modem

Abstract— We evaluate the stability of two-way time and frequency transfer over a 50 km fiber optic link established using a commercially available fiber optic modem. For this evaluation we report the

[pmc.ncbi.nlm.nih.gov](https://pubmed.ncbi.nlm.nih.gov)

Hier sollte eine Beschreibung angezeigt werden, diese Seite lässt dies jedoch nicht zu.

Understanding Propagation Delay and Its Role in Networks

Propagation delay is a factor in large-scale data center networks relying on extensive fiber optic cabling. Understanding this delay helps optimize resource allocation and improve

Introduction to Fiber Optic Delay Line and Applications in ...

Application scenarios In some advanced optical communication systems, such as quantum communication and photonic integrated circuits, fiber optic delay lines

Optical Delay Lines: Fiber-Based Devices for Timing Adjustment in ...

Explore the pivotal role of optical delay lines in satellite communication systems, focusing on their function in enhancing signal integrity and enabling precise timing adjustments. This article delves into

FREE Optical Fibre Latency Calculator

We've teamed up with our colleagues from M2 Optics to bring you our new Optical Fibre Latency Calculator. This useful reference tool will quickly calculate precise

Time Delay Measurement in Optical Fibers Based on Phase Detection

We developed an efficient and accurate fiber transfer delay measurement system. The main principle is to convert the fiber transfer delay in time domain into the phase detection, and eliminating the

Stabilized Time Transfer via a 1000-km Optical Fiber

Variations in optical fiber length and refractive index are induced by environmental perturbation, resulting in an additional dynamic propagation delay

Fiber-optic delay line using multicore fiber

A fiber-optic delay line based on a multicore optical fiber is fabricated for the first time. Due to the optical pulse sequential passage over all cores, the time delay of the optical signal of 45.0

Fiber Optic Distance Calculator Based on Time Delay

Fiber optic cables revolutionized global communications, enabling high-speed data transfer over long distances with minimal signal loss. Light signals transmitted through fiber optics

Understanding Modal Dispersion in Optical Fibers

Understanding Modal Dispersion in Optical Fibers Introduction to Modal Dispersion
Modal dispersion is a critical phenomenon in optical fiber communications that affects the quality and

Contact Us

For more information, pricing, or custom solutions, please contact us:

Website: <https://tooltechnologyapplication.com.pl>

Email: info@tooltechnologyapplication.com.pl

Phone: +49 69 3527 4819

Address: Neue Mainzer Straße 66, 60311 Frankfurt, Germany

This document is for informational purposes only. Specifications subject to change without notice.

